

Interpreting a Human Pedigree

Use the pedigree below to answer 1-5

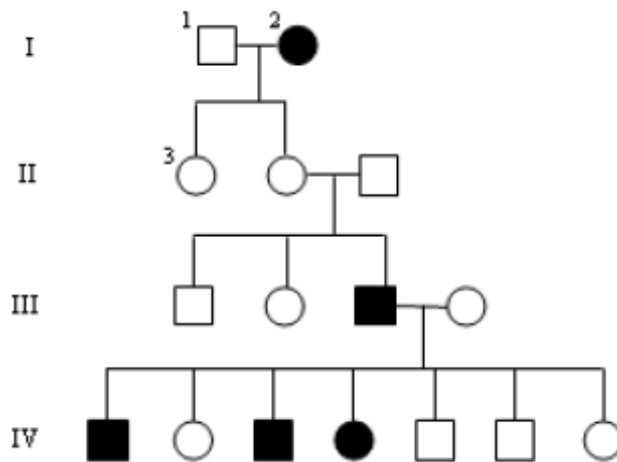

1. In a pedigree, a square represents a male. If it is *darkened* he has *hemophilia*; if clear, he had normal blood clotting.

a. How many males are there? _____

b. How many males have hemophilia? _____

2. A circle represents a female. If it is *darkened*, she has *hemophilia*; if open she is normal.

a. How many female are there? _____

b. How many females have hemophilia? _____

3. A marriage is indicated by a horizontal line connecting a circle to a square.

a. How many marriages are there? _____

4. A line perpendicular to a marriage line indicates the offspring. If the line ends with either a circle or a square, the couple had only one child. However, if the line is connected to another horizontal line, then several children were produced, each indicated by a short vertical line connected to the horizontal line. The first child born appears to the left and the last born to the right.

a. How many children did the first couple (couple in row I) have? _____

b. How many children did the third couple (couple in row III) have? _____

5. Level I represent the first generation, level II represents the second generation.

a. How many generations are there? _____

b. How many members are there in the fourth generation? _____

Use the pedigree below to answer 6-12

Shaded individuals have Huntington's Disease

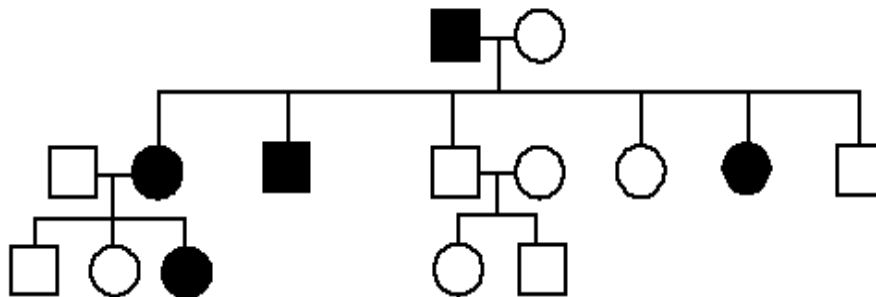

6. Write the generation on the pedigree numbers (roman numerals).

7. Which members of the family above are afflicted with Huntington's Disease? _____

8. There are no carriers for Huntington's Disease- you either have it or you don't.

With this in mind, is Huntington's disease caused by a dominant or recessive trait? _____

9. How many children did individuals I-1 and I-2 have? _____

10. How many girls did II-1 and II-2 have? _____ How many have Huntington's Disease? _____

11. How is individual III-2 and II-4 related? _____ I-2 and III-5? _____

12. Write the genotypes of each individual on the pedigree.

Use the Pedigree below to answer 13-18

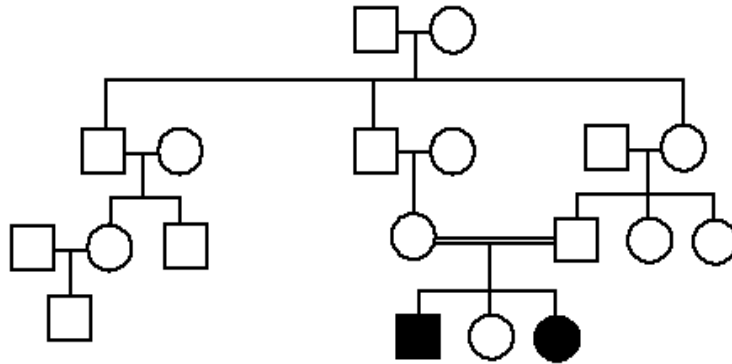

13. Write the generation on the pedigree numbers (roman numerals).
The pedigree to the above shows the passing on of Hitchhiker's Thumb in a family. Is this trait dominant or recessive? _____
14. How do you know? _____
15. How are individuals III-1 and III-2 related? _____
16. Name 2 individuals that have hitchhiker's thumb. _____
17. Name 2 individuals that were carriers of hitchhiker's thumb. _____
18. Write the genotypes for each individual on the pedigree. _____

Determining Inheritance Patterns

19. When working through a pedigree, the first thing you need to do is figure out which characteristic is dominant – the shaded one or the un-shaded one. Then you need to choose a letter (let's use A) and begin assigning genotypes. Remember that recessive individuals are **always** homozygous, so assign their genotypes first. Then go back and look at all of the dominant individuals. For some, you will only be able to determine one allele of the genotype, so just write the one capital allele followed by a question mark (A?).

- a. Which characteristic is dominant? _____
- b. Which characteristic is recessive? _____
- c. Determine the genotypes of all individuals. You will have three "A?". Write your Genotypes beneath each individual.

Fur Color in Mice

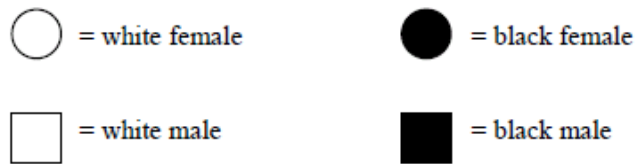
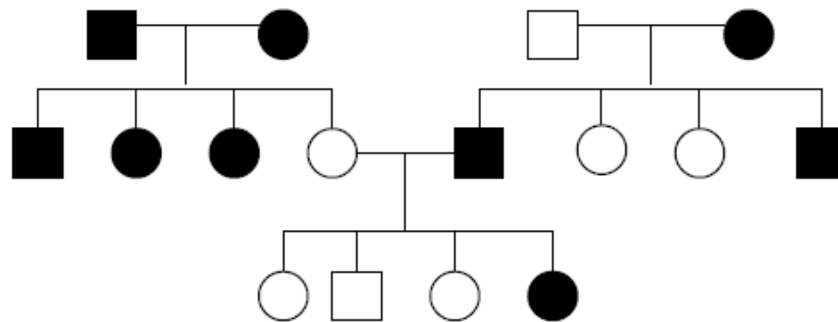

20. Is the trait dominant or recessive? _____

Write the genotype for each individual (use the letter A)

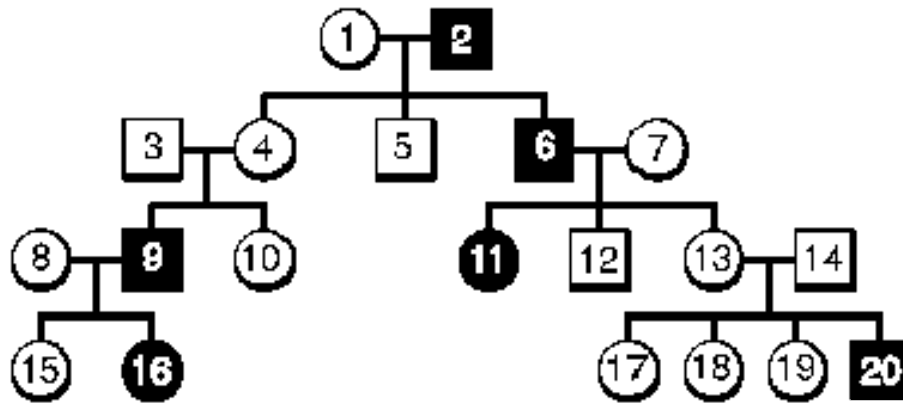

21. Is the trait dominant or recessive? _____

Write the genotype for each individual (use the letter A)

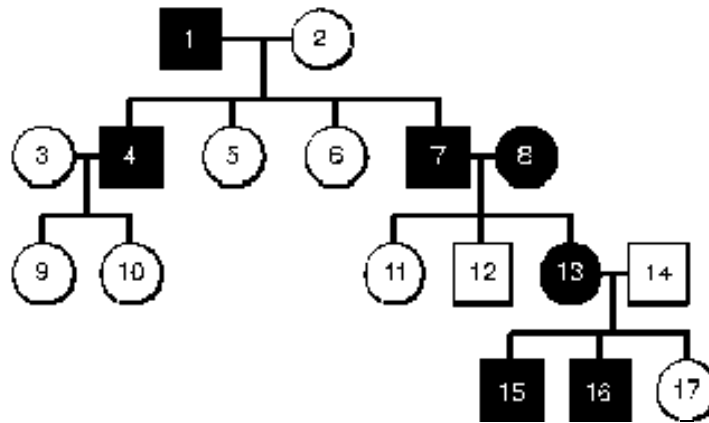

Making Conclusions

22. If a child has an autosomal dominant trait, what can you say about the parents?

23. If two parents have an autosomal dominant trait, what can you say about their children?

24. If two parents have an autosomal recessive trait, what can you say about their children?

25. If two parents do not have an autosomal recessive trait, what can you say about their children?

26. Can autosomal recessive traits skip generations?